

SEMÁFORO TIPO VEHICULOS MODELO 3 /200 VAR CON PANTALLA DE CONTRASTE

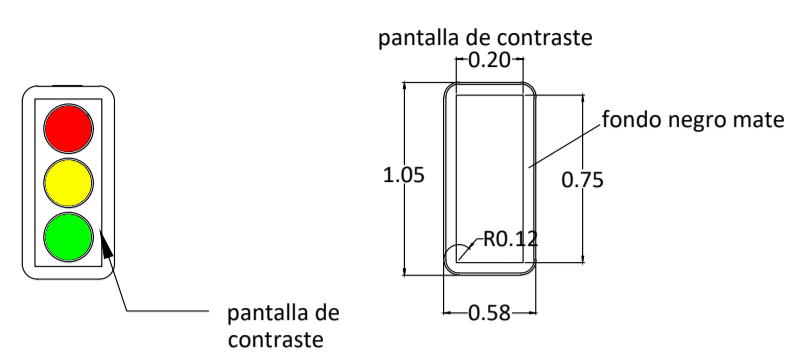

SEMÁFORO TIPO VEHICULOS MODELO 3 /200 VAR

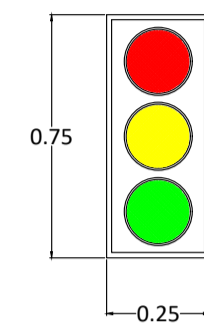

SEMÁFORO TIPO PEATONES/BICICLETAS MODELO 2 /200 VAR

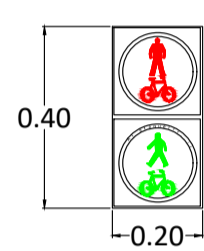

SOPORTES SEMAFOROS

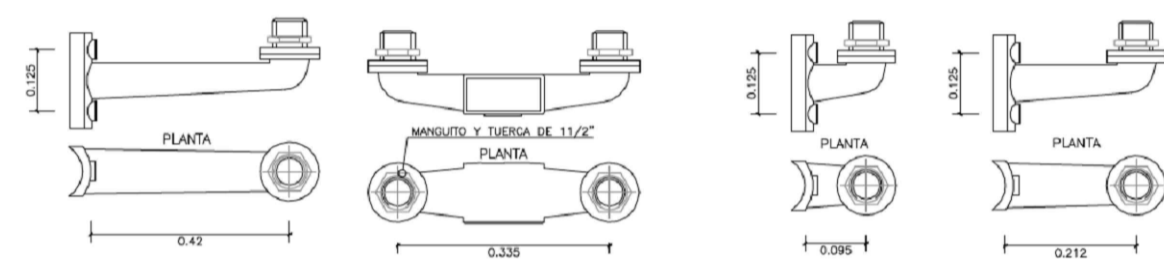

COLUMNA DE 2.40 METROS DE ALTURA

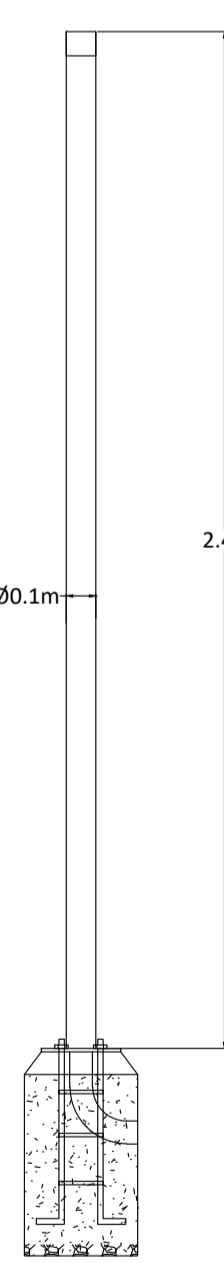

AVISADOR ACÚSTICO

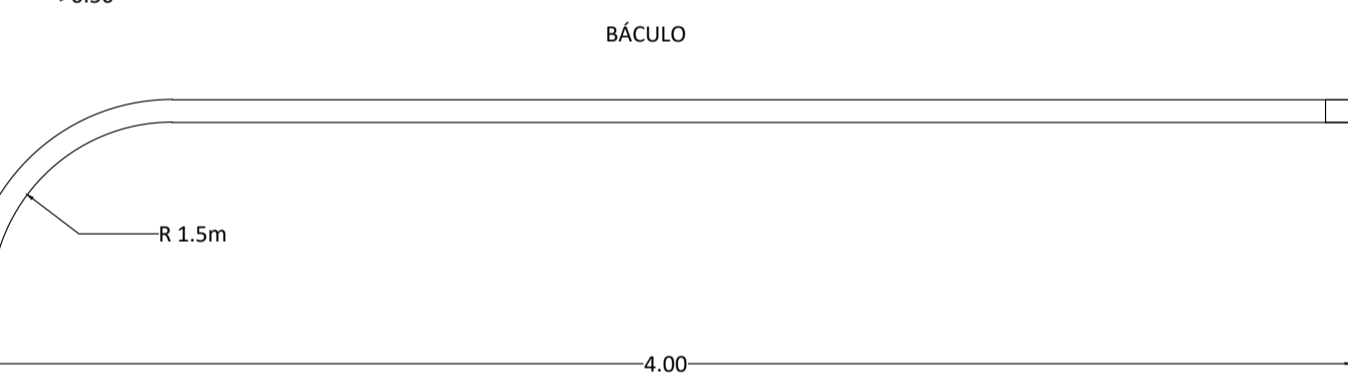
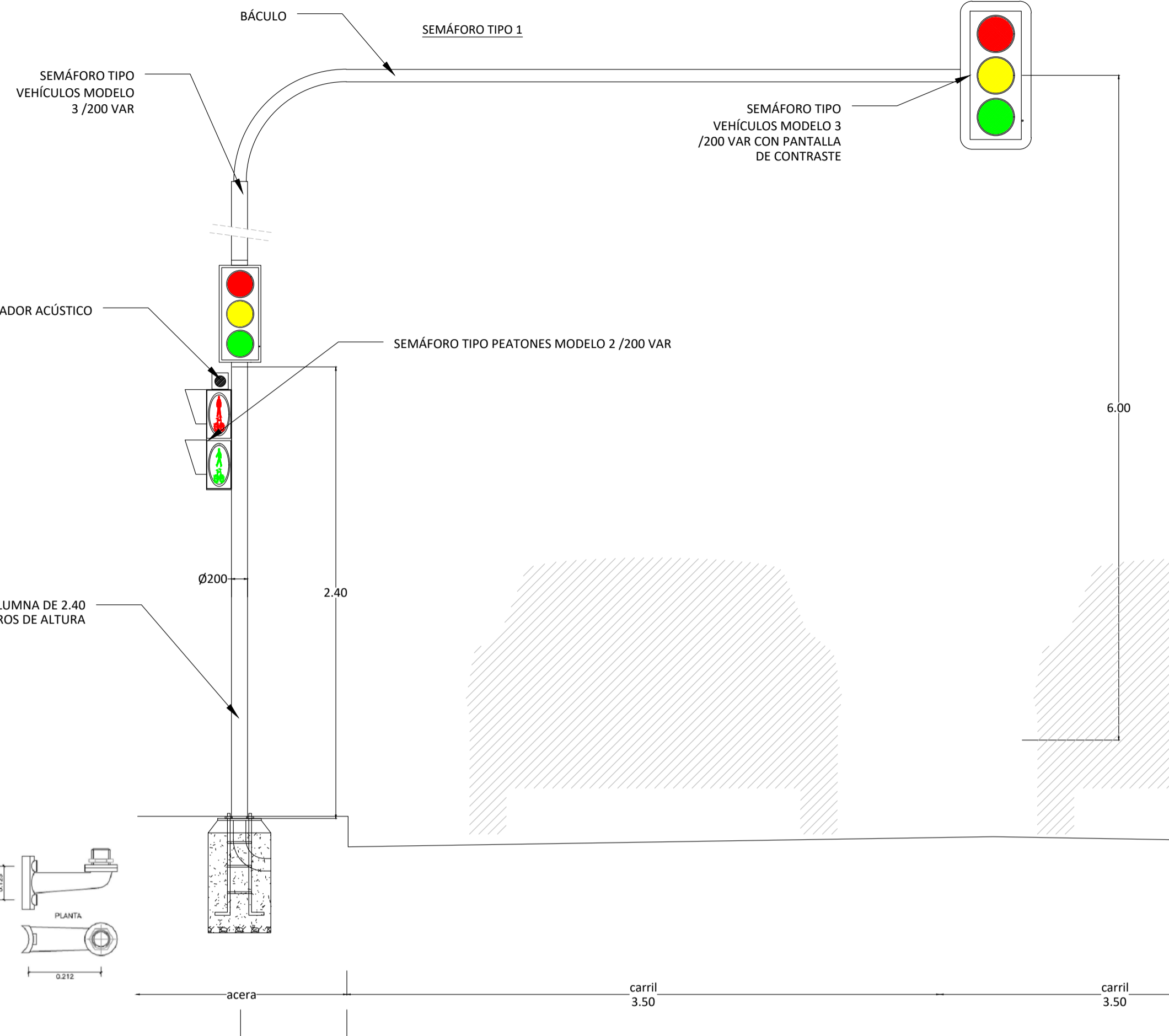

SEMÁFORO TIPO 2

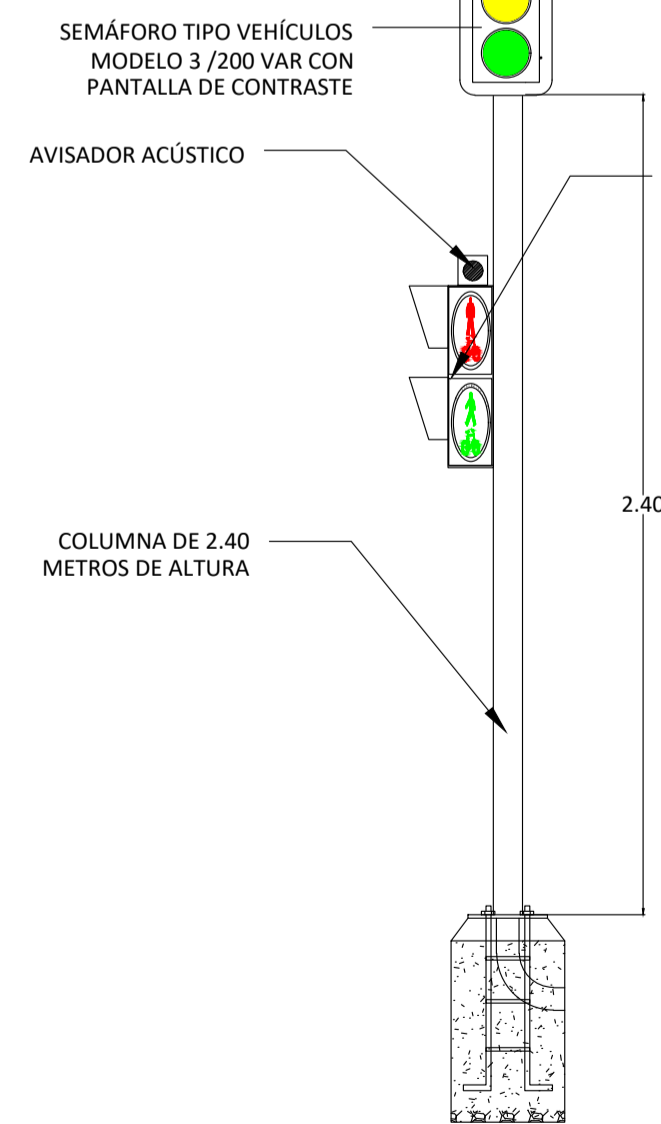

CIMENTACION

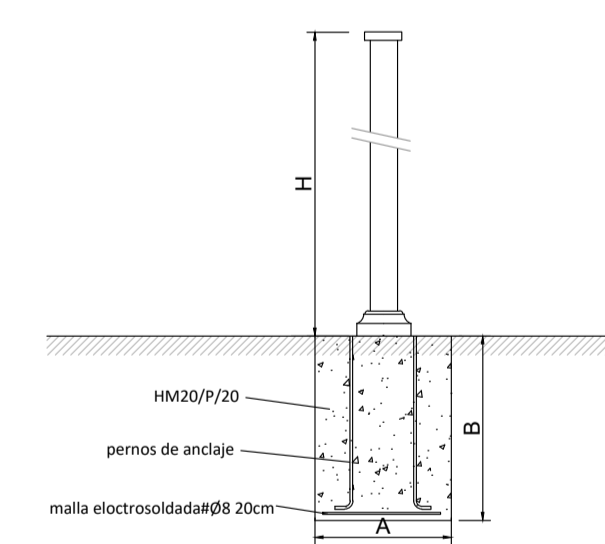

ALTA BACULO (m)	DIMENSIONES CIMENTACION (mm)		PERNOS DE ANCLAJE	
	A	B	LONGITUD (mm)	DIÁMETRO (mm)
2.4	400	700	600	16
6	1000	1100	1000	16

ARMARIO DE DISTRIBUCIÓN URBANA (ADU)

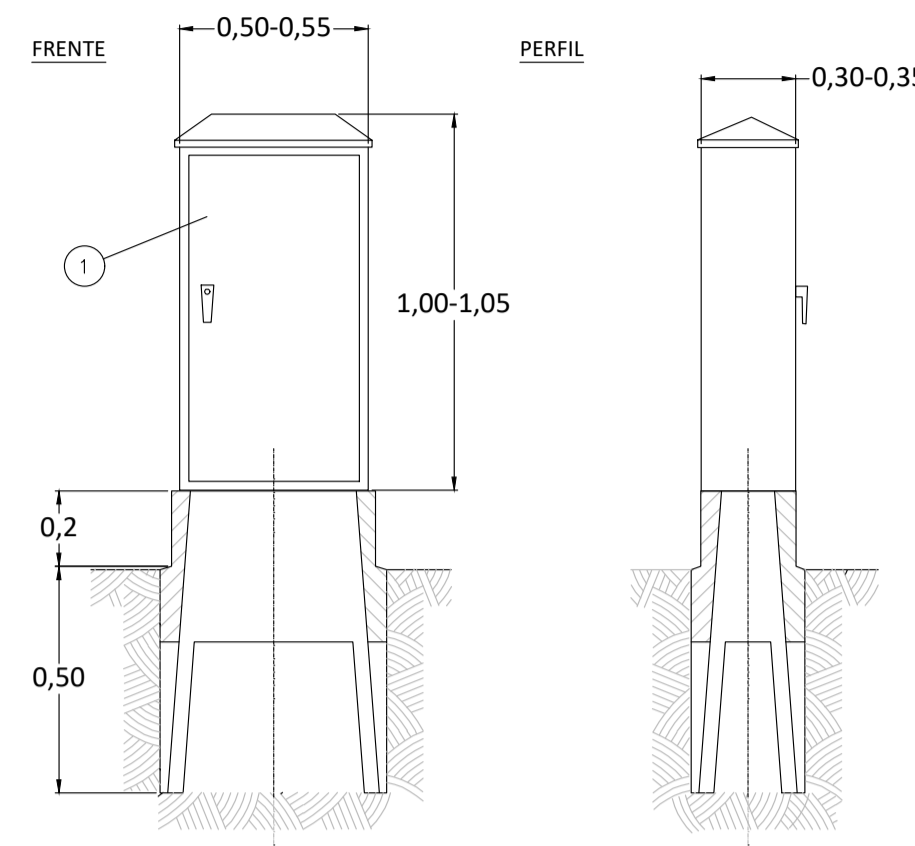

DETALLE ARMARIO DE DISTRIBUCIÓN URBANA

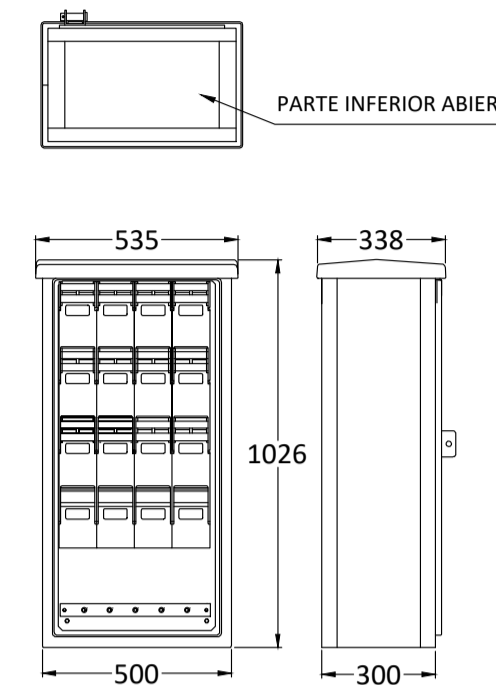

CONJUNTO MONTADO

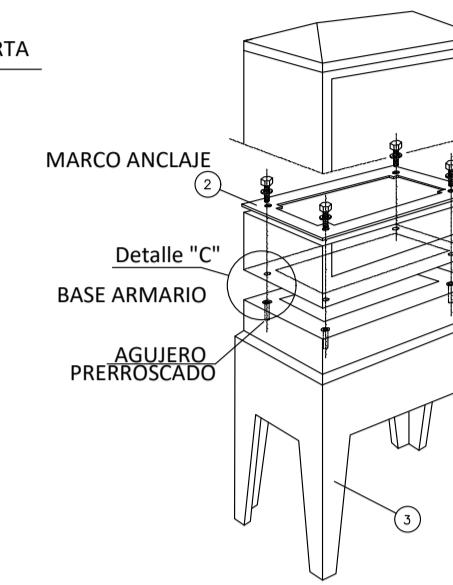

PLANTA PEANA

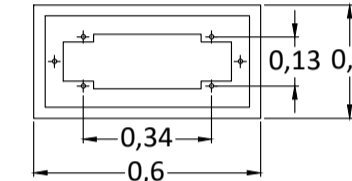

DETALLE C

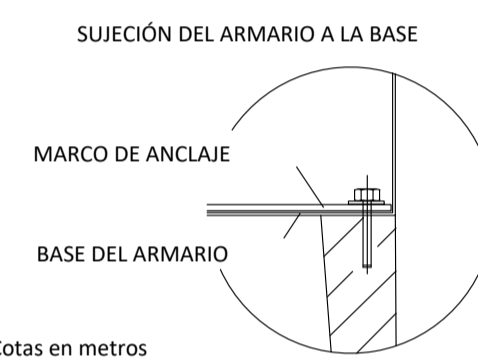

MARCO DE ANCLAJE

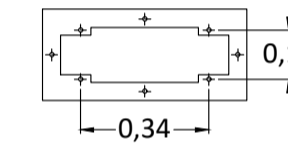

POSICIÓN	MATERIALES
1	Armario de distribución urbana - ADU
2	Herraje fijación armario distribución urbana
3	Zócalo prefabricado armario distribución urbana Hormigón reforzado con fibra de vidrio. CEM / 52.5 R

NOTA 1: Las imágenes representadas son orientativas y no prejuzgan el diseño final de la aparatada
Cotas en metros

ZANJA CANALIZACION SEMAFOROS

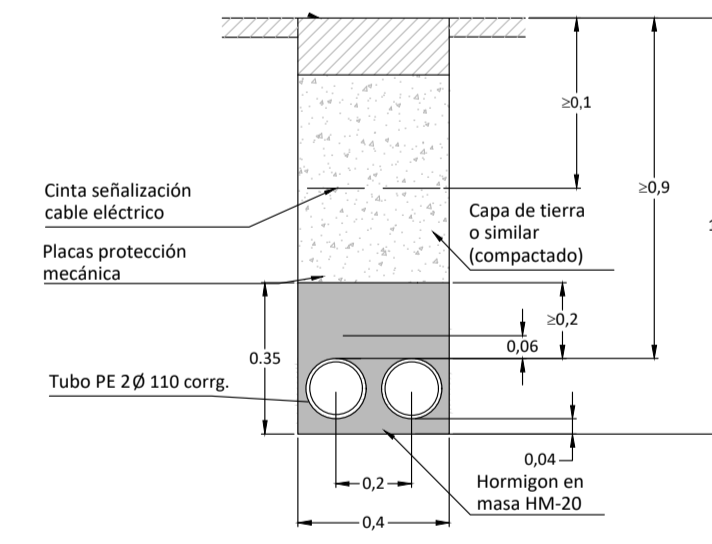

ZANJA CANALIZACION SEMAFOROS

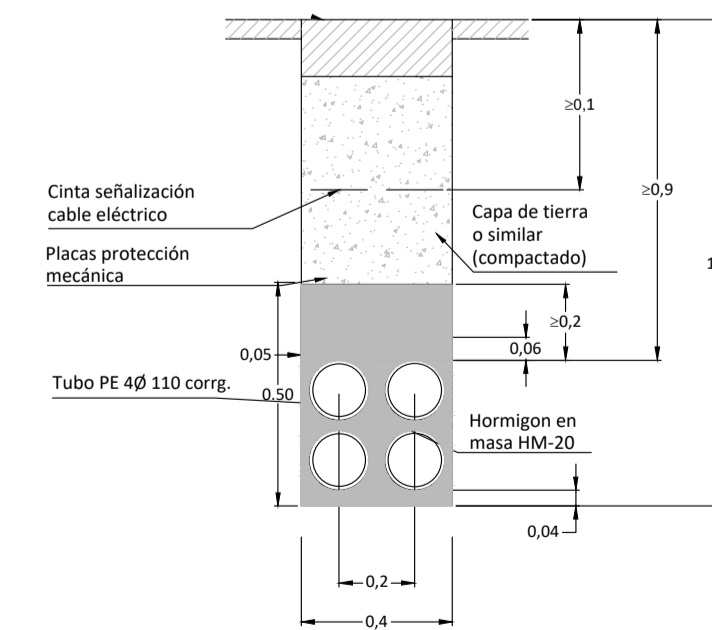

ARQUETA DE REGISTRO PARA SEMAFORIZACION DE 60x60 cm. CON TAPA DE FUNDICIÓN (C250). S/E COTAS EN m.

